

AUTOGARD SERIES 400

ADDITIONAL MODELS

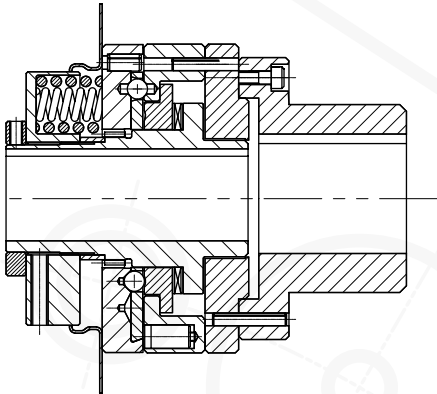

Model 404

A rigid coupling style used when the attached unit is self aligning

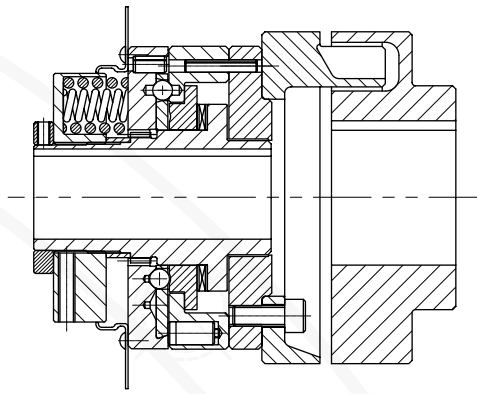

Model 406N

A torsionally soft flexible coupling providing a failsafe design.

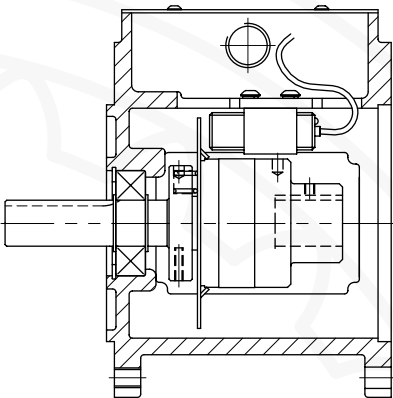

Model 408

An interposed style designed to fit between a standard motor & gearbox

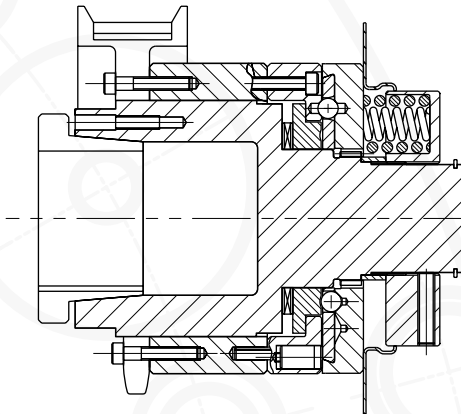

Model 409 TB

Standard 409 bored to suite standard industrial bushings

AUTOGARD SERIES 400

SPECIAL DESIGNS

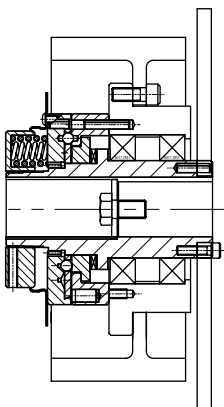

Model 409 c/w large pulley and brake

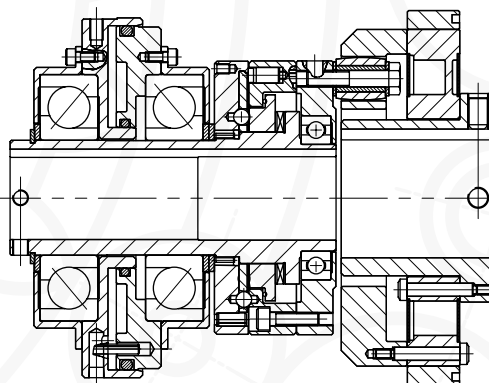

Air actuated Model 403 c/w a flexible coupling and a Monitorq torque monitoring system.

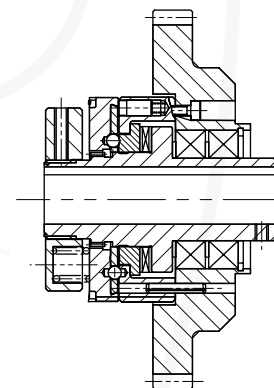

Model 402 c/w a custom gear